



## Series 10 Filling Head for VFFS Machines

The All-Fill Series 10 VFFS filling head provides the perfect configuration when integrated with a vertical-form-fill-seal bagging system.

The sleeved mount permits rotation of the filling head for ease of tooling/hopper removal.



### Standard Features

- ▼ OEM swivel mount
- ▼ All stainless-steel contact parts
- ▼ 38 litre stainless steel hopper
- ▼ No-tools removable change parts
- ▼ Auger machined from solid
- ▼ Servo-driven auger
- ▼ Independent agitation drive
- ▼ PLC control via touch-screen panel
- ▼ Siemens PLC-based weigh-fill controller
- ▼ Integrated control cabinet to match VFFS machine

### Options

- ▼ Product Recipe Memory
- ▼ Lean-Clean 56 Litre Split Hopper
- ▼ Hopper Level Probe
- ▼ Bulk Feed Accessories
- ▼ Full stainless-steel specification
- ▼ 316L contact parts
- ▼ Check-weigher feedback
- ▼ Single and twin acting flap valves
- ▼ Jacking system
- ▼ Gassing system for sensitive powders

**All-Fill International Ltd**

Unit 5 Gateshead Close | Sunderland Road | Sandy | Bedfordshire | SG19 1RS | United Kingdom

 +44(0)1767 691100

 [info@allfill.co.uk](mailto:info@allfill.co.uk)

 [www.allfill.co.uk](http://www.allfill.co.uk)

# Series 10 Filling Head for VFFS Machines

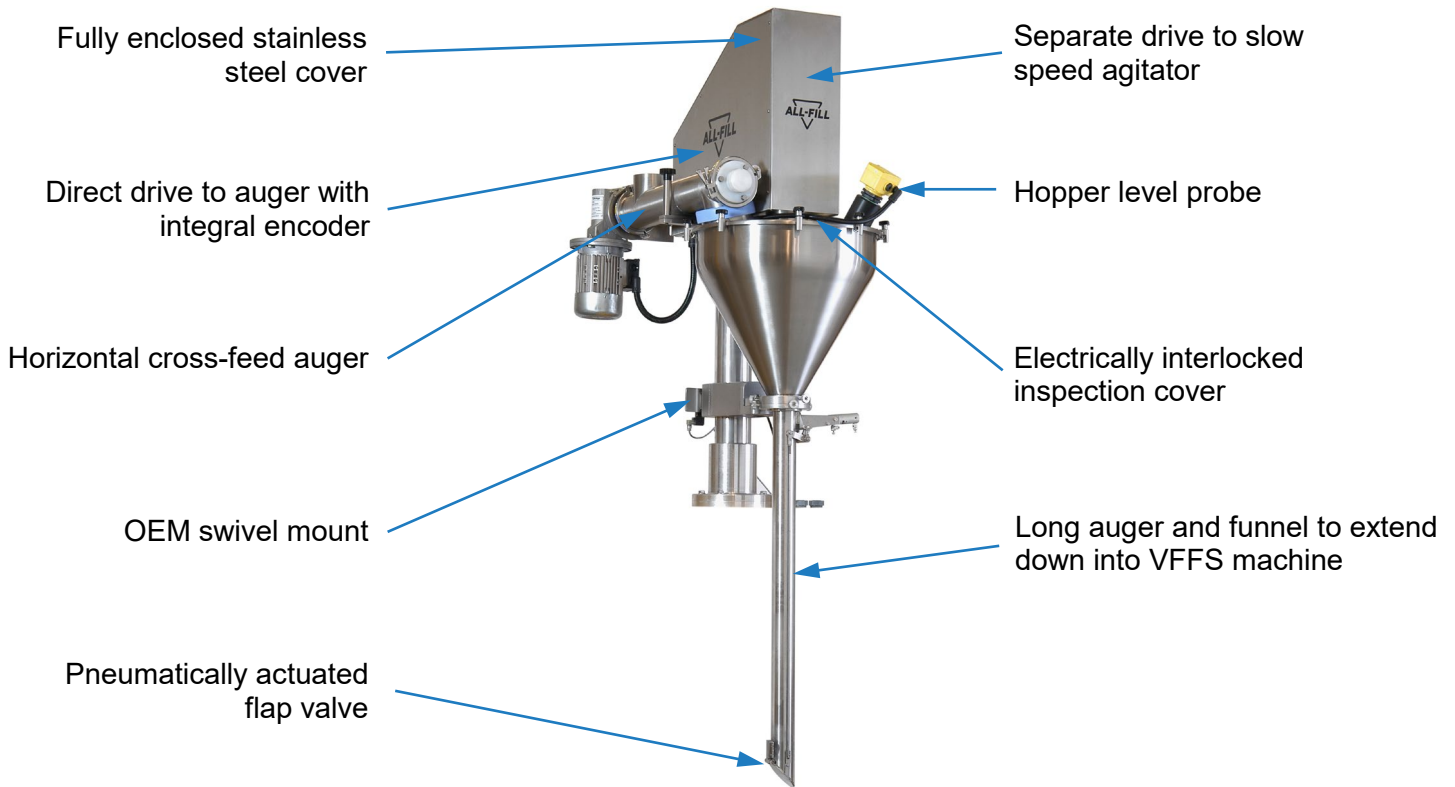

## Standard Specification

Controller type:	Siemens PLC	Hopper capacity:	38 litres
HMI:	Colour touch-screen panel	Auger revs:	0.0003 rev incremental adjustment
Agitation drive:	0.55kW	Auger tooling:	Manufactured from solid steel
Agitation options:	Continuous	Contact parts:	304 grade stainless steel
	With fill only	Fill weight range:	20mg – 50kg
	With fill and time delay	Power:	2.2 kva
	No agitation	Weight:	175kg

## Typical Bulk Feed Options

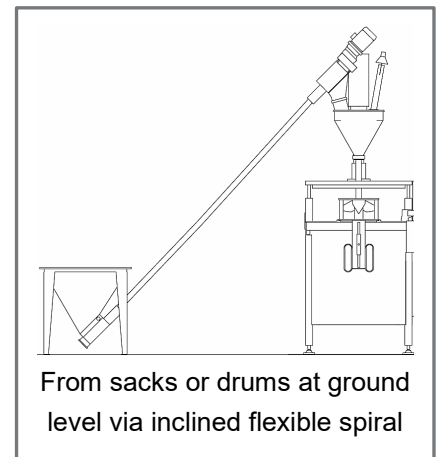
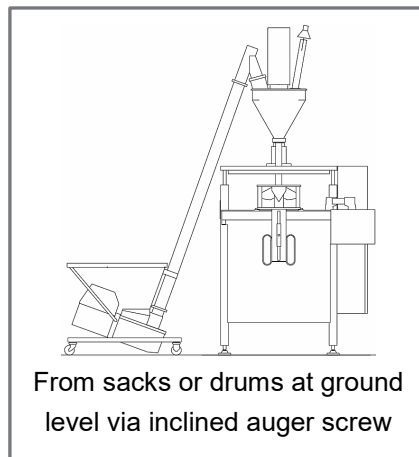
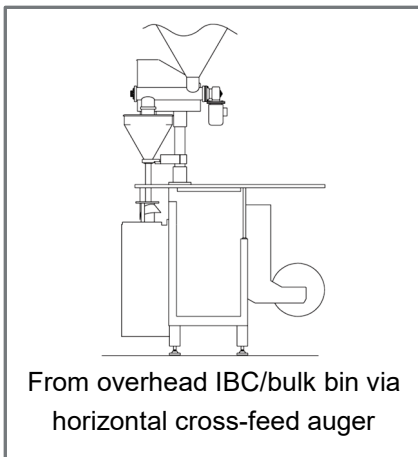

**All-Fill International Ltd**

Unit 5 Gateshead Close | Sunderland Road | Sandy | Bedfordshire | SG19 1RS | United Kingdom

+44(0)1767 691100

info@allfill.co.uk

www.allfill.co.uk